

Overview of PROW Permits

Outdoor Display Area: \$75 annual permit

Displays must be kept free of graffiti and must not be a hazard to pedestrian traffic (see Illustration V-A for placement restrictions)

Proper displays that are safe and stable with no risk of overturning only; folding tables or cardboard boxes do not qualify

Allowed (some maximum quantity limits apply):

- Books, magazines & musical instruments
- Produce, baked goods & food in glass containers
- Cut or live flowers & plants
- Clothing & accessories (on mannequins/hangers – NO RACKS)
- Hand crafted products & goods
- Artwork (paintings, photography, sculpture, frames, pottery)
- Sports equipment, bicycles & luggage
- Wooden, metal or patio furniture (NO mattresses or sofas)
- Leather goods & rugs
- Pet accessories (excluding pet food)
- Other merchandise similar in character, type or nature to those listed above with approval from NPMS

Not Allowed:

- Alcohol, tobacco, cigarettes or smoking accessories
- Upholstered items with a cumulative height/width/depth of 9+ ft
- Shoes (except those displayed on mannequins or props)
- Vending & dispensing equipment
- Appliances & mattresses
- Canned or prepackaged foods
- Adult-oriented material
- Auto-related merchandise
- DVDs, CDs, videotapes, cassettes etc.
- Computers, home or office electronics
- Cameras and photographic equipment
- Live animals & pet food
- Pawned items
- Weapons (guns, knives, fencing swords, antique pistols etc.)
- Home cleaning products or personal care items

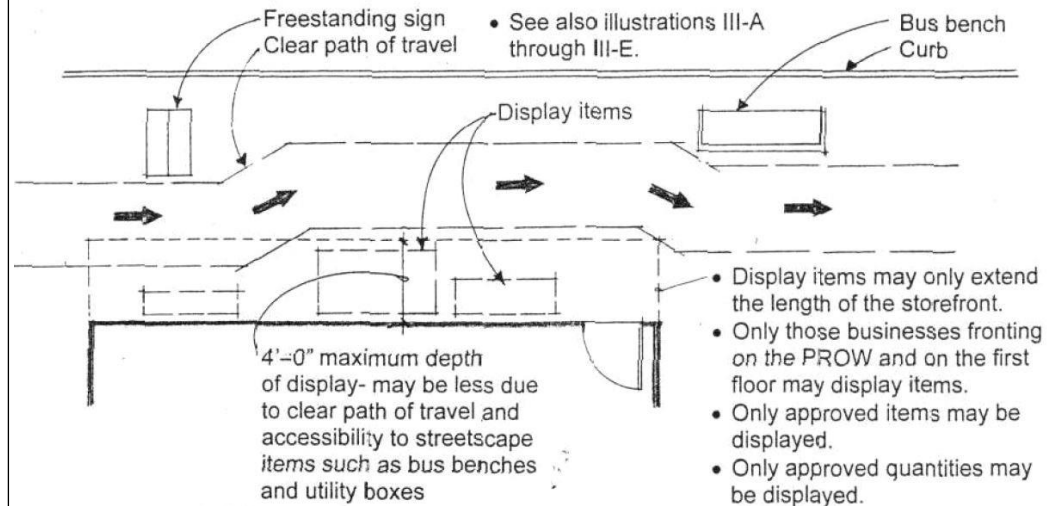

Illustration V-A: Location of Display Items in the PROW

This illustration exhibits the specific requirements of the enhancement standards and is intended only as an aid.

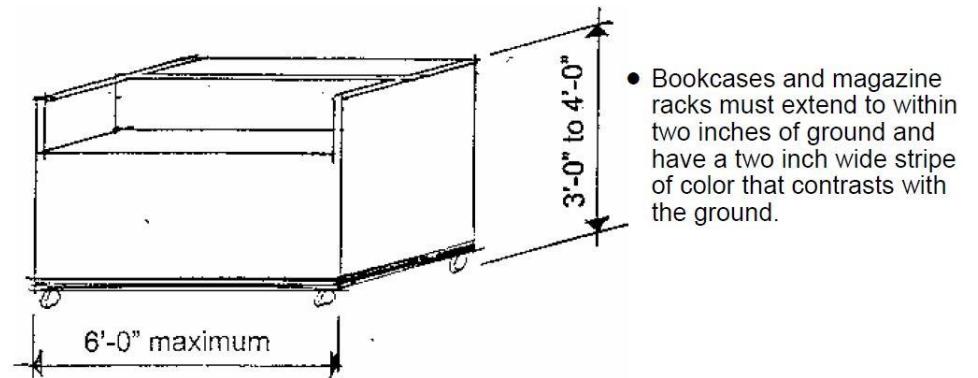

Illustration V-B: Book and Magazine Racks

This illustration exhibits the specific requirements of the enhancement standards and is intended only as an aid.

Freestanding Sign: \$50 annual permit

- Maximum footprint shall be 2'-0" x 3'-0" with a height between 3'-0" and 4'-0". Signs shall be designed to stand alone, with no more than two faces per sign
- Signs shall be placed in the PROW, but NOT within 2 feet of the curb, in the clear path of travel or in clear areas adjacent to street furniture
- Sign must be placed directly in front of the business it represents. No live advertising is allowed (character actors or staff holding promotional signage)
- Signs shall be brought inside when weather creates potentially hazardous conditions. No glass, breakable material or sharp edges

SALLY'S TV AND VCR REPAIR

MON-FRI 9 AM TO 6 PM
SAT 9 AM TO 3 PM
TWO-DAY SERVICE

SPECIAL FOR THIS WEEK:
CLEAN YOUR DVD PLAYER
FOR \$25.00

Illustration IV-A: Purpose

This illustration exhibits the specific requirements of the enhancement standards and is intended only as an aid.

- Identify the business, indicate it is open, and list its hours of operation
- Show restaurant menus and daily specials
- Advertise sales, specials deals, and special services

PHIL'S DELI

OPEN M-F 7-3

TODAY'S SPECIALS:

CLAM CHOWDER \$2.00
BAR-B-Q BEEF
SANDWICH WITH SODA
AND CHIPS \$3.95



Illustration IV-B:

Size, Appearance, and Design

This illustration exhibits the specific requirements of the enhancement standards and is intended only as an aid.

- A-frame style.
- Signboard to continue to the ground.
- The bottom 2" of the signboard shall be of a contrasting color to that of the ground.
- Sign to be of professional quality.
- Sign to be made of durable materials.
- No sharp edges or corners.
- No paper signs.
- No balloons, windsocks, pinwheels, or other wind-activated items.

Outdoor Dining Area: \$150 annual permit

- Sale and consumption of alcohol requires an additional City of San Diego Sidewalk Café Permit
- Tables and chairs must be in good condition and made of sturdy materials. Umbrellas shall be fire-treated
- Permanent lighting may be added in compliance with City code – lighting must attach to building
- Hours of operation are not to exceed those of the primary use
- May use all of the area in the PROW adjacent to the business except the area required for a clear path for travel or access to street furniture/utility boxes or areas within 2 feet of the curb
(**Exception:** PROW area within 2 feet of curb may be used if parking is head-on rather than parallel)

*Requires submittal of 2 copies of scale drawings of usage boundaries, property lines, existing obstructions, etc.

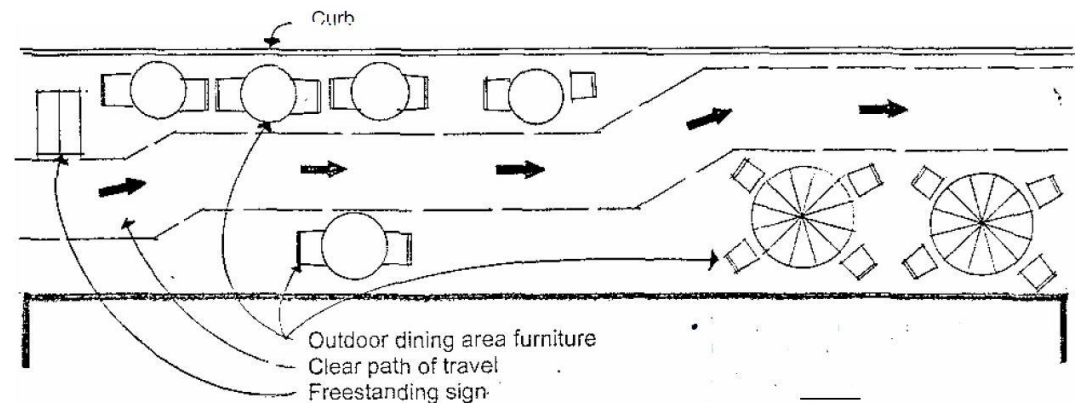

Illustration VI-B- Location of Outdoor Dining Area in the Public Right of Way

This illustration exhibits the specific requirements of the enhancement standards and is intended only as an aid.

travel, including path of travel to street furniture such as bus stops and utility boxes as well as the entrance to the restaurant.

- See also illustrations III-A through III-E.